

ALUMÍNIAZSÍVANYAGÚ SZÉLES VILÁGÍTÓPÁLYA

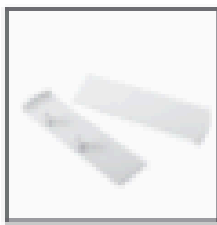

Decolino

mennyezeti rögzítéssel
mounted on the ceiling



Gyártó:
SZINTETIKA KFT. | H-9023 Győr, Mészáros L. u. 5.
Tel.: +36-96/618-200
www.szintetika.hu

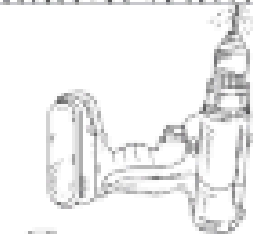

1.

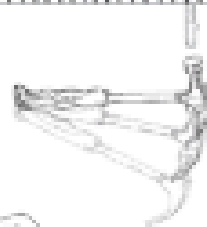

2.

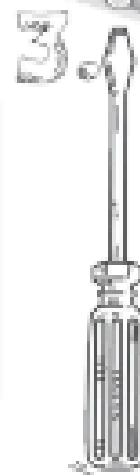

3.



4.

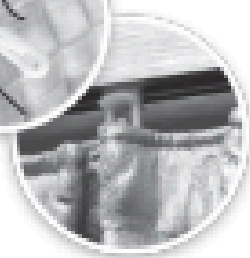

5.

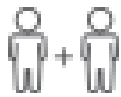

ÁLLÍTSÁK FEL A TARTÓRAKAT A FALRA ÉS A TARTÓRAKAT A TARTÓRAKRA.

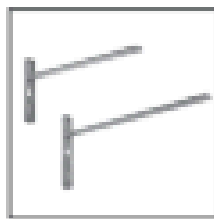
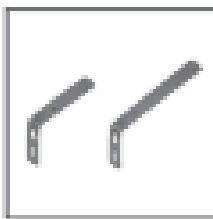
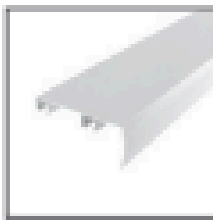
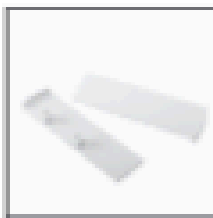

Decolino

fali tartóval
with wall bracket



Gyártó:
SZINETIKA KFT. | H-9023 Győr, Mézeshegy L. u. 5.
Tel.: +36-96/618-200
www.szinetika.hu

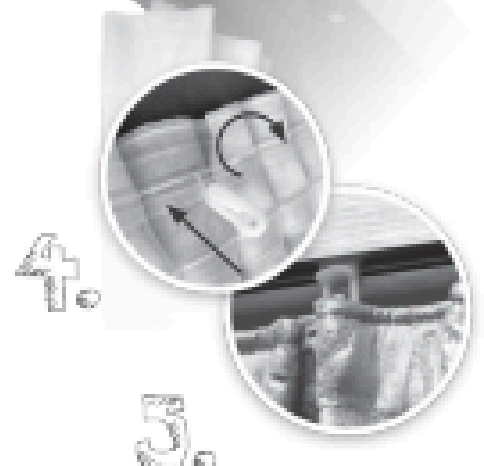
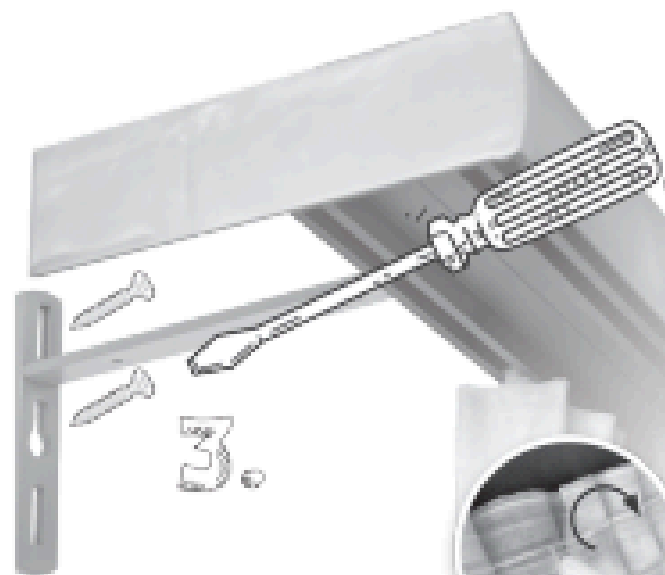
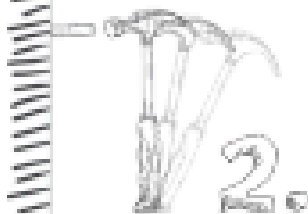

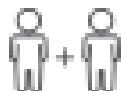

ÁLLAPOTBAN VAN A FELTÉTELEK A SZERELÉSHEZ? KÉRJÜNK, HOGY KÖVETKEZŐN KÉRJEN FELMÉRÉST A SZERELÉSHEZ!

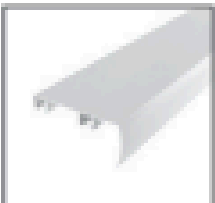
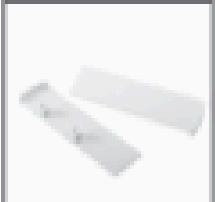

Decolino karnis

Optimo tartóval
with Optimo bracket



Gyártó:
SZINETIKA KFT. | H-9023 Győr, Mészáros L. u. 5.
Tel.: +36-96/618-200
www.szinetika.hu

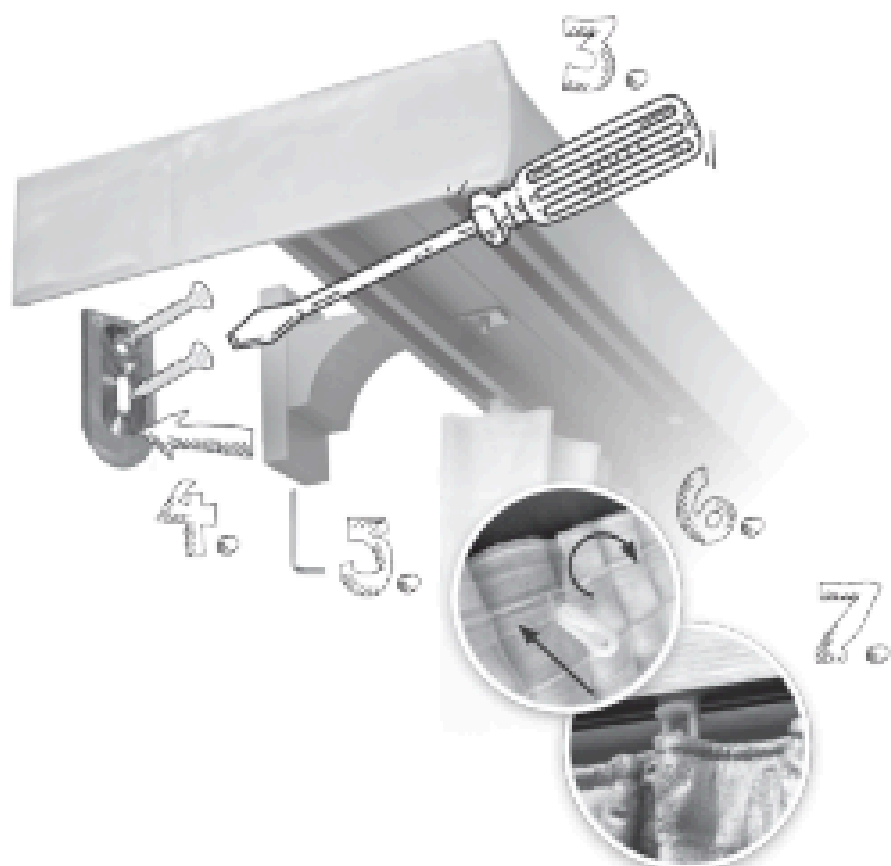
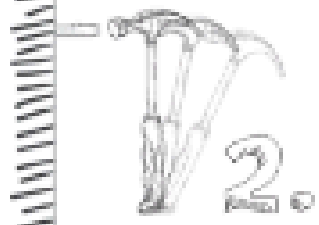

▪ **FIGYELEM!** A karnis helytelen rögzítéséből adódó balesetek súlyos, akár végzetes sérüléseket okozhatnak. Ahhoz, hogy megakadályozza, hogy ez a karnis leessen, a karnist megfelelően a falhoz kell rögzítenie. Mindig válasszon olyan csavart, rögzítőt, tiplít, mely a leginkább alkalmas az otthonában található fal minőségéhez és ellenőrizze, hogy a teherbíró képessége is megfelelő legyen. A karnis és alkatrészei kizárólag függöny- és textil-árnyékolók felfogatására alkalmas termékek. Nem minősül rendeltetésszerű használatnak az ettől eltérő minőségű, súlyú termék/eszköz függesztése, felakasztása. Garanciális és szavatossági kötelezettségeinknek csak a kezelési utasítás és rendeltetésszerű használat betartása mellett tudunk eleget tenni.

▪ **Tisztítás:** Száraz ruhával törölje tisztára.

▪ **Összeállítás:** A karnis felszereléséhez két személy szükséges.

FIGYELEM! Az apró alkatrészek lenyelése fulladásveszélyt okozhat. A kisgyermek megfulladhatnak a nyakuk köré tekeredő húzózsinór miatt, amelyek a



termék működtetésére szolgálnak. A fulladás és beakadás megelőzése érdekében kisgyermekektől tartsa távol a zsinórokat. Ne legyen ágy és egyéb bútor a karnisszerkezetek húzózsinórja közelében. A zsinórokat ne kösse össze. Ügyeljen rá, hogy a zsinórok ne tekeredjenek össze, és ne képezzenek hurkot.

Gyártja és forgalmazza | Vyrobcce a distributor | Vyrobcce a distribútor
Produced and distributed by | Producător și distribuitor | Proizvedeno i distribuiru
Szintetika Kft. | H-9023 Győr, Mészáros L. u. 5. | Tel.: +36-96/618-200
www.szintetika.hu